

ECH10 Horizontale mehrstufige Edelstahlpumpe

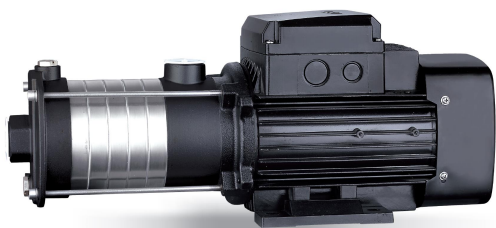

ECH

Application

- Wasserversorgung für Hochhäuser, Pumpstationen, Überdruckwaschstationen
- Heizwasserzirkulation, Klimaanlage Wasserzirkulation, Wasseraufbereitungssysteme
- Ultrafiltrationssysteme, Umkehrosmose, Systeme, kommunale Schwimmbäder
- Bewässerung: Besprengung, Tropf
- Industrie
- Feuerlöschanlagen

Pompe

- Edelstahlwelle
- Maximale Flüssigkeitstemperatur: + 85 ° C
- Maximale Saughöhe: 8 m
- Maximaler Betriebsdruck: 10 bar
- pH zwischen 4 und 10

Moteur

- IE3-Motor Schutzklasse
- : IP55
- Isolationsklasse: F
- Maximale Umgebungstemperatur: + 40 °
- Integrierter Wärmeschutz für einphasige Versionen
- Höhe: bis 1000 m

Identifikationscodes

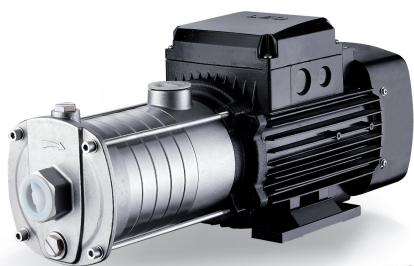
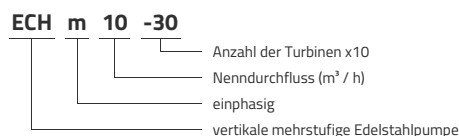

ECHS

Technische Daten

MODEL	kW	Q (m ³ /h)	6	7	8	9	10	11	12
		Q (l/min)	100	117	133	150	167	183	200
ECHm10-10	0.75	9.1	8.7	8.2	7.7	6.8	5.8		
ECH10-10	0.75	9.1	8.7	8.2	7.7	6.8	5.8		
ECHm10-20	0.75	17.9	17.1	16.3	15.3	14	12.5	10.6	
ECH10-20	0.75	17.9	17.1	16.3	15.3	14	12.5	10.6	
ECHm10-30	1.1	27.1	26.3	24.9	23.4	21.4	19.3	16.9	
ECH10-30	1.1	27.1	26.3	24.9	23.4	21.4	19.3	16.9	
ECHm10-40	1.5	38.6	37.6	35.9	33.9	31.2	28.2	24.6	
ECH10-40	1.5	38.6	37.6	35.9	33.9	31.2	28.2	24.6	
ECHm10-50	2.2	47.8	46.4	44.4	42.2	39.5	35.9	31.1	
ECH10-50	2.2	47.8	46.4	44.4	42.2	39.5	35.9	31.1	

Maße

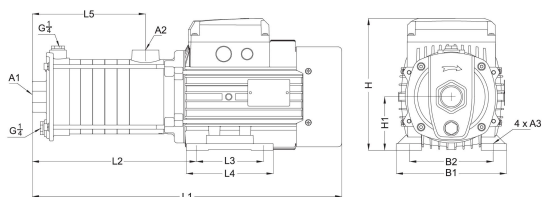

MODEL	L1	L2	L3	L4	L5	B1	B2	H	H1	A1	A2	A3
ECHm10-10	430	212	100	130	121	165	125	204.5	80	1½	1¼	10
ECH10-10	430	212	100	130	121	165	125	204.5	80	1½	1¼	10
ECHm10-20	430	212	100	130	121	165	125	204.5	80	1½	1¼	10
ECH10-20	430	212	100	130	121	165	125	204.5	80	1½	1¼	10
ECHm10-30	460.5	242.5	100	130	151.5	165	125	504.5	80	1½	1¼	10
ECH10-30	460.5	242.5	100	130	151.5	165	125	504.5	80	1½	1¼	10
ECHm10-40	549.5	261.5	125	150	182	180	140	217.5	90	1½	1¼	10
ECH10-40	549.5	261.5	125	150	182	180	140	217.5	90	1½	1¼	10
ECHm10-50	579.5	291.5	125	150	212	180	140	217.5	90	1½	1¼	10
ECH10-50	579.5	291.5	125	150	212	180	140	217.5	90	1½	1¼	10

Hydraulische Leistung

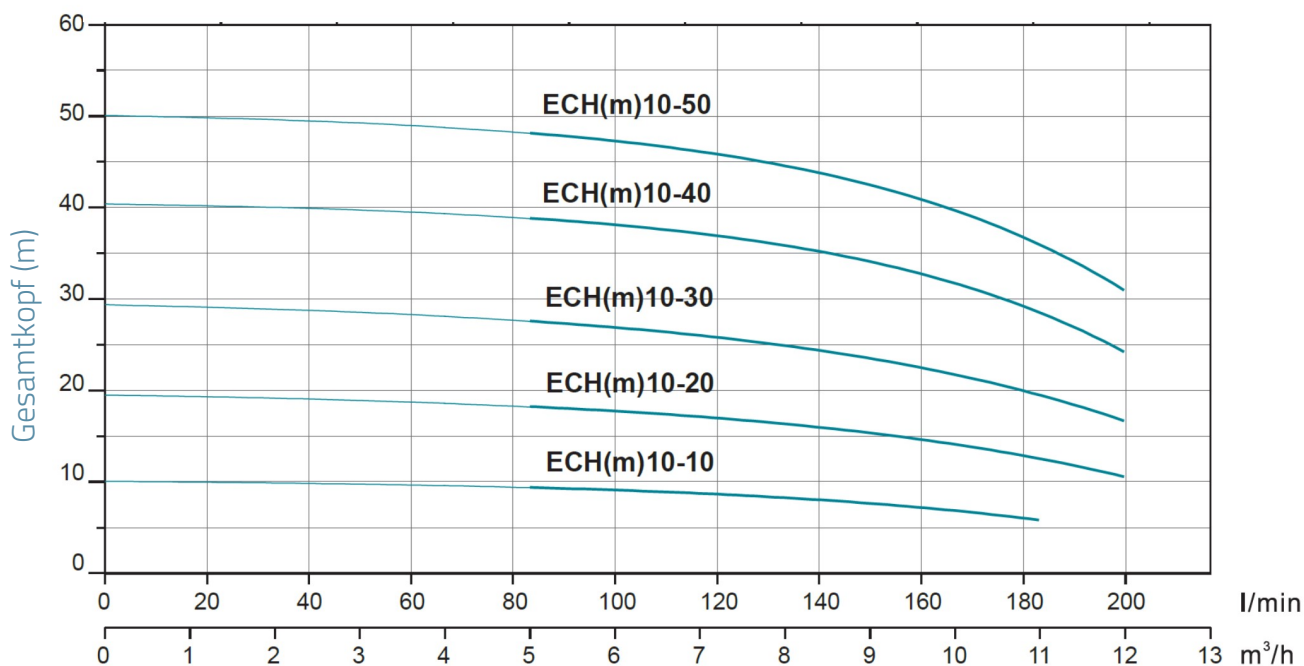

Explosionszeichnung

No.	Type	Materialien
1	Lüfterabdeckung	Stahl 08F
2	Ventilator	Polypropylen
3	hintere Lagerunterstützung des Motors	Aluminiumguss ZL102
4	Rotor	
5	rollen	
6	Klemmenkastenabdeckung	Aluminiumguss ZL102
7	Stator	
8	Laterne	Gusseisen HT200
9	Auslassdiffusor	Gusseisen HT200
10	Gleitringdichtung	Siliciumcarbide / Graphit
11	Shim	Edelstahl AISI 304
12	Streamer	Edelstahl AISI 304
13	Lager	Edelstahl AISI 304
14	Turbine	Edelstahl AISI 304
15	Vorderseite	Gusseisen HT200
16	Dichtung	PTFE

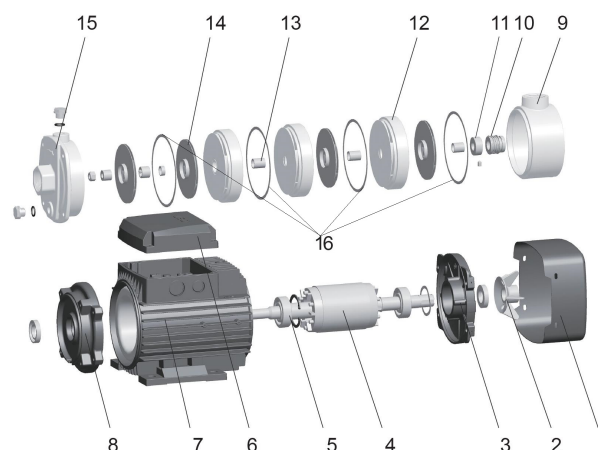

Packaging

MODEL	Gewicht (kg)	Länge L (mm)	Breite W (mm)	Höhe H (mm)
ECHm10-10	20.7	503	235	268
ECH10-10	20.7	503	235	268
ECHm10-20	20.8	503	235	268
ECH10-20	20.8	503	235	268
ECHm10-30	21.9	503	235	268
ECH10-30	21.9	503	235	268
ECHm10-40	28.2	618	245	283
ECH10-40	28.2	618	245	283
ECHm10-50	30.6	618	245	283
ECH10-50	30.6	618	245	283

