

ECH4-D Horizontal multistage stainless steel pump

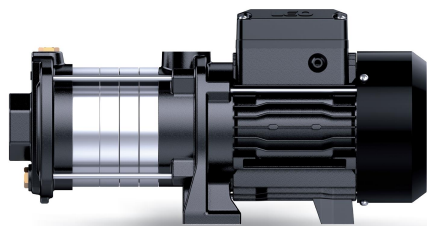

Application

- Water supply for tall buildings, pumping stations, overpressure
- Washing stations, heating water circulation, air conditioning water circulation, water treatment systems
- Ultrafiltration, reverse osmosis, distillation systems, municipal swimming pools
- Irrigation: sprinkling, drip
- Industry
- Fire fighting systems

Pompe

- Stainless steel shaft
- Max liquid temperature: +40°C
- Max suction height: 8 m
- Maximum operating pressure: 5.5 bar
- pH between 6,5 and 8,5

Moteur

- IE3 motor
- Protection class: IP55
- Insulation class: F
- Maximum ambient temperature: +40°
- Integrated thermal protection for single-phase versions
- Altitude: up to 1000 m

Identification codes

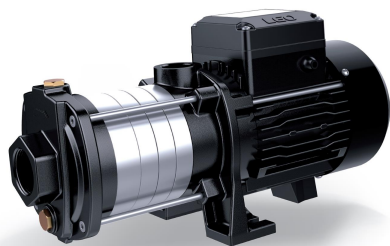
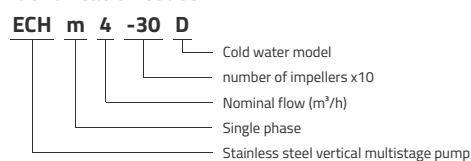

Technical data

MODEL	kW	Q (m ³ /h)	1	2	3	4	5	6	7
		Q (l/min)	17	33	50	67	83	100	117
ECHm4-20-D	0.55		17	16	15	13	12	10	8
ECH4-20-D	0.55		17	16	15	13	12	10	8
ECHm4-30-D	0.55		27	25	23	21	19	16	13
ECH4-30-D	0.55		27	25	23	21	19	16	13
ECHm4-40-D	0.75		36	34	32	28	26	22	17
ECH4-40-D	0.75		36	34	32	28	26	22	17

Dimensions

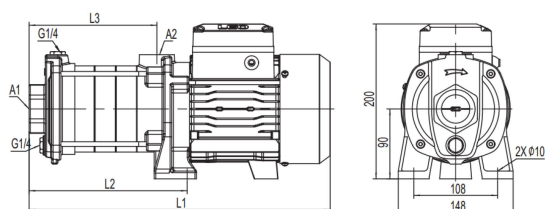

MODEL	L1	L2	L3	A1	A2
ECHm4-20-D	334	150	111	1 1/4	1
ECH4-20-D	334	150	111	1 1/4	1
ECHm4-30-D	361	177	138	1 1/4	1
ECH4-30-D	361	177	138	1 1/4	1
ECHm4-40-D	388	204	165	1 1/4	1
ECH4-40-D	388	204	165	1 1/4	1

Hydraulic performance

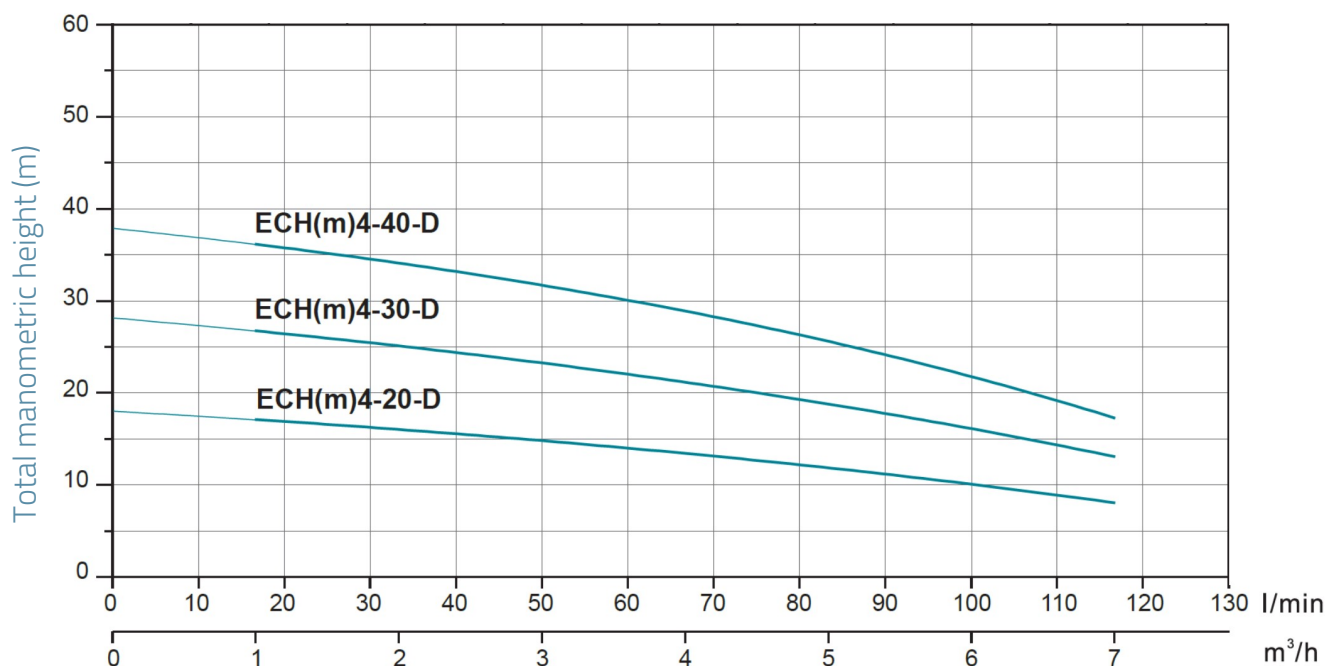

Exploded view

No.	Type	Materials
1	Front cover	cast iron HT200
2	Positioning sleeve	AISI 304 stainless steel
3	Circlip	PolyTetraFluoroEthylene
4	Diffuser	AISI 304 stainless steel
5	Impeller	AISI 304 stainless steel
6	Muff	AISI 304 stainless steel
7	Mechanical seal	silicon carbide / graphite
8	Fan cover	08F steel
9	Fan	polypropylene
10	Rear cover	cast aluminum ZL102
11	Bearing	
12	Stator	
13	Rotor	
14	Lantern	cast iron HT200
15	Circlip	PolyTetraFluoroEthylene
16	Leg	PolyTetraFluoroEthylene

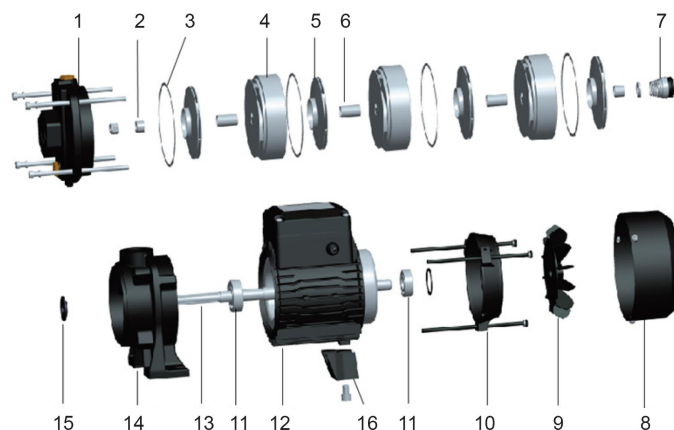

Packaging

MODEL	Weight (kg)	Length L (mm)	Width W (mm)	Height H (mm)
ECHm4-20-D	12	375	185	237
ECH4-20-D	11.7	375	185	237
ECHm4-30-D	12.6	420	185	237
ECH4-30-D	12.4	420	185	237
ECHm4-40-D	14	420	185	237
ECH4-40-D	13.8	420	185	237

