

EDH15 Horizontal multistage pump made entirely of stainless steel

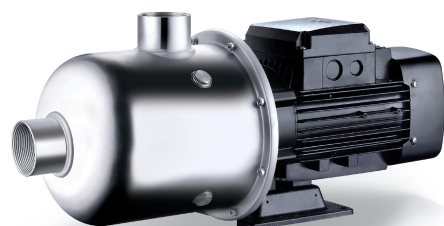
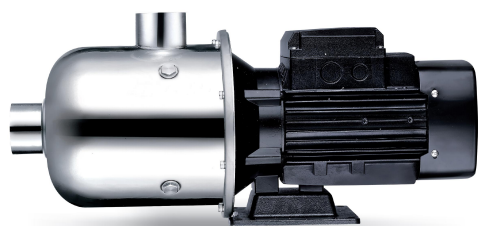

Application

- Water supply for tall buildings, pumping stations, overpressure
- Washing stations, heating water circulation, air conditioning water circulation, water treatment systems
- Ultrafiltration, reverse osmosis, distillation systems, municipal swimming pools
- Irrigation: sprinkling, drip
- Industry
- Fire fighting systems

Pompe

- Stainless steel shaft
- Max liquid temperature: +85°C
- Max suction height: 8 m
- Maximum operating pressure: 10 bars
- pH between 4 and 10

Moteur

- IE3 motor
- Protection class: IP55
- Insulation class: F
- Maximum ambient temperature: +40°
- Integrated thermal protection for single-phase versions
- Altitude: up to 1000 m

Identification codes

EDH m 15 -30

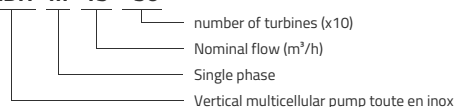

Technical data

MODEL	kW	Q (m³/h)									
		9	11	13	15	17	19	22	25	28	
		Q (l/min)	150	183	217	250	283	317	367	417	467
EDHm15-10	1.1		11.6	11	10.4	9.7	9.1	8.5	7.7	5.9	4.8
EDH15-10	1.1		11.6	11	10.4	9.7	9.1	8.5	7.7	5.9	4.8
EDHm15-20	2.2		25.4	24.5	23.4	22.2	21.1	19.7	17.4	15	12
EDH15-20	2.2		25.4	24.5	23.4	22.2	21.1	19.7	17.4	15	12
EDH15-30	3		38.4	37.2	35.8	34.1	32.3	30.2	26.6	22.8	18.8

Dimensions

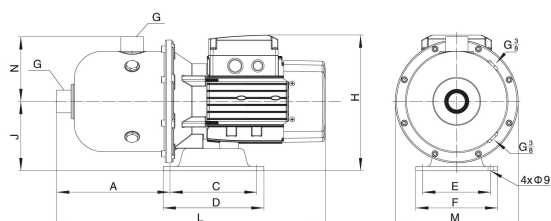

MODEL	L	A	C	D	E	F	G	H	J	M	N
EDHm15-10	568	278	138	160	108	130	2	245	120	233	140
EDH15-10	568	278	138	160	108	130	2	245	120	233	140
EDHm15-20	626	287	138	160	108	130	2	248	120	233	140
EDH15-20	626	287	138	160	108	130	2	248	120	233	140
EDH15-30	626	287	138	160	108	130	2	248	120	233	140

Hydraulic performance

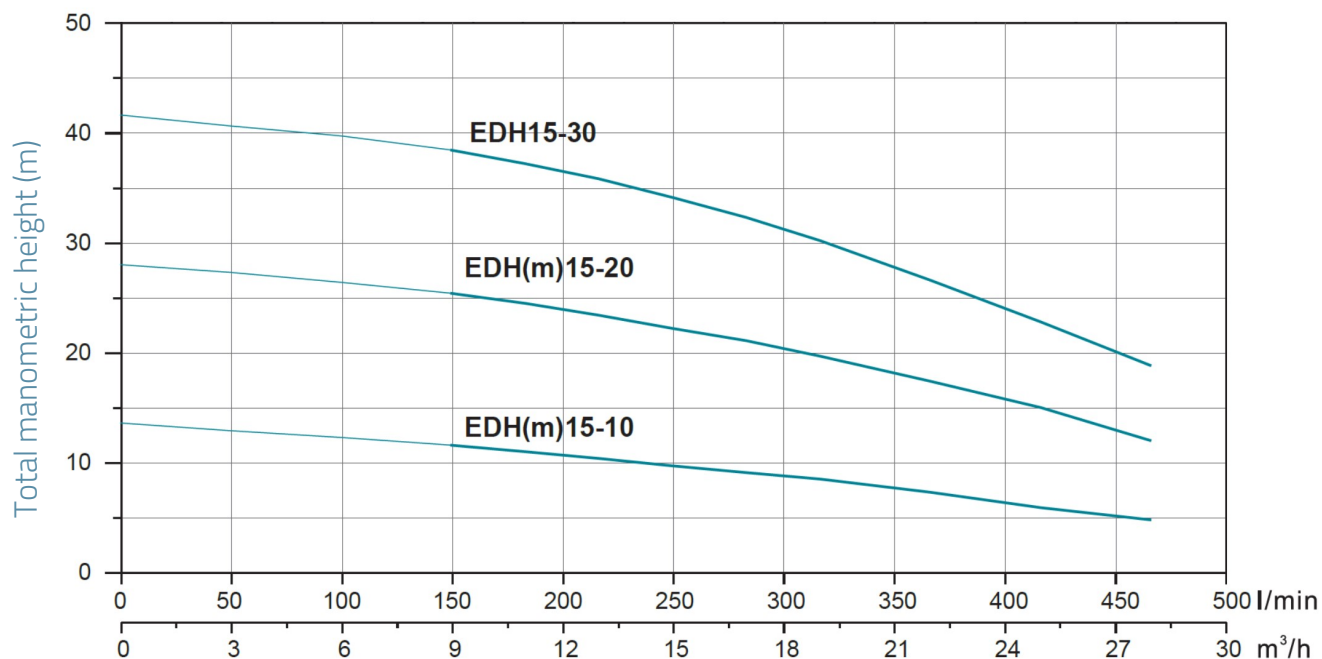

Exploded view

No.	Type	Materials
1	Pump body	AISI 304 stainless steel
2	Lantern	cast aluminum ZL102
3	Motor support	cast iron HT200
4	Stator	
5	Rotor	
6	Bearing	
7	Rear cover	cast aluminum ZL102
8	Fan	polypropylene
9	Fan cover	08F steel
10	Pump bottom	AISI 304 stainless steel
11	Mechanical seal	silicon carbide / graphite
12	Shim	AISI 304 stainless steel
13	Diffuser	AISI 304 stainless steel
14	Diffuser	AISI 304 stainless steel
15	Bearing	AISI 304 stainless steel
16	Impeller	AISI 304 stainless steel
17	Diffuser	AISI 304 stainless steel
18	Front plate	AISI 304 stainless steel
19	Spacer sleeve	AISI 304 stainless steel

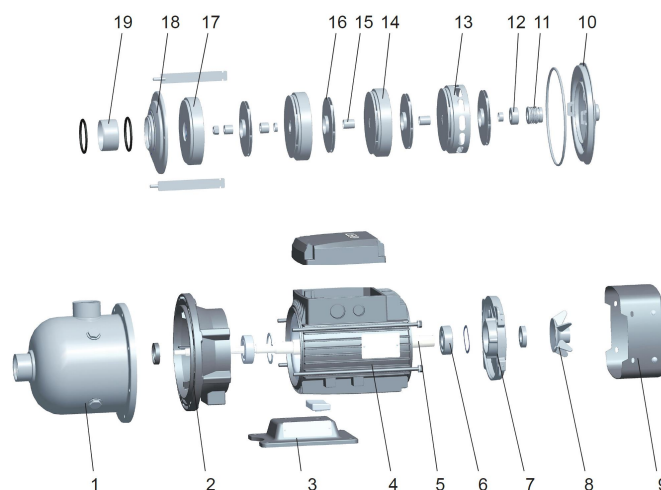

Packaging

MODEL	Weight (kg)	Length L (mm)	Width W (mm)	Height H (mm)
EDHm15-10	20.5	610	265	317
EDH15-10	20.5	610	265	317
EDHm15-20	28.8	660	265	317
EDH15-20	28.8	660	265	317
EDH15-30	33	660	265	317

