

Scope of Performance LVS (R)

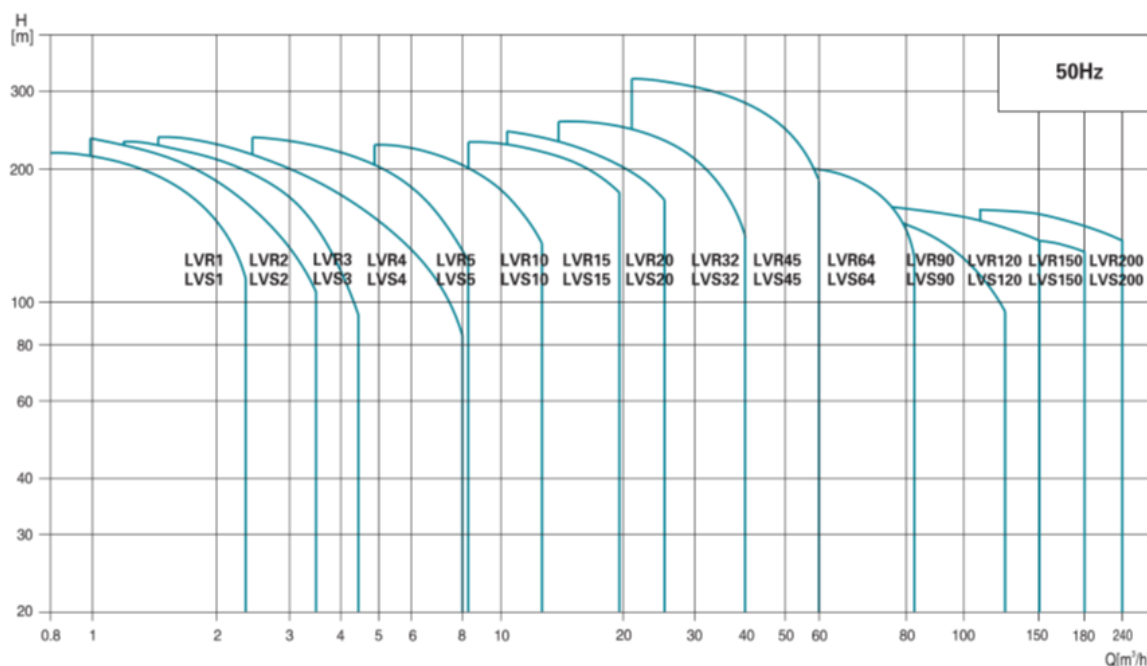

Product Range

MODEL	LVR(S)1	LVR(S)2	LVR(S)3	LVR(S)4	LVR(S)5	LVR(S)10	LVR(S)15	LVR(S)20	LVR(S)32	LVR(S)45	LVR(S)64	LVR(S)90	LVR(S)120	LVR(S)150	LVR(S)200
DESCRIPTION															
Rated flow [m³/h]	1	2	3	4	5	10	15	20	32	45	64	90	120	150	200
Flow range [m³/h]	0.7-2.4	1.0-3.5	1.2-4.5	1.5-8	2.5-8.5	5-13	8-23	10.5-29	15-40	22-58	30-85	45-120	60-150	80-180	100-240
Max. pressure [bar]	22	23	24	21	24	22	23	25	28	33	22	20	16	16	16
Motor power [kW]	0.37-2.2	0.37-3	0.37-3	0.37-4	0.37-4	1.1-7.5	1.1-15	1.1-18.5	1.5-30	3-45	4-45	5.5-45	11-75	11-75	18.5-110
Temperature Range [°C]	-20°C--+120°C (Note: Both the Max. permissible pressure and liquid temperature range refer to the pump capacity.)														
Max. pump efficiency [%]	45	46	55	59	60	65	70	72	78	79	80	81	74	73	79
Pipe connection-LVR															
Oval flange	G1	G1	G1	G1 1/4	G1 1/4	-	-	-	-	-	-	-	-	-	-
DIN flange	DN25	DN25	DN25	DN32	DN32	DN40	DN50	DN50	DN65	DN80	DN100	DN100	DN125	DN125	DN150
Pipe connection-LVS															
Oval flange	-	-	-	-	-	-	-	-	-	-	-	-	-	-	-
DIN flange	DN32	DN32	DN32	DN32	DN32	DN40	DN50	DN50	DN65	DN80	DN100	DN100	DN125	DN125	DN150
Clamp connector	φ42	φ42	φ42	φ42	φ42	-	-	-	-	-	-	-	-	-	-
Threaded connector	R ₂ 1 1/4	R ₂ 1 1/4	R ₂ 1 1/4	R ₂ 1 1/4	R ₂ 1 1/4	-	-	-	-	-	-	-	-	-	-

Ambient Temperature

An ambient temperature of over 40 ° C or an installation at an altitude above 1000 meters above sea level requires an oversized motor. Due to low air density and poor cooling, the output power P_2 decreases, as shown in the table below:

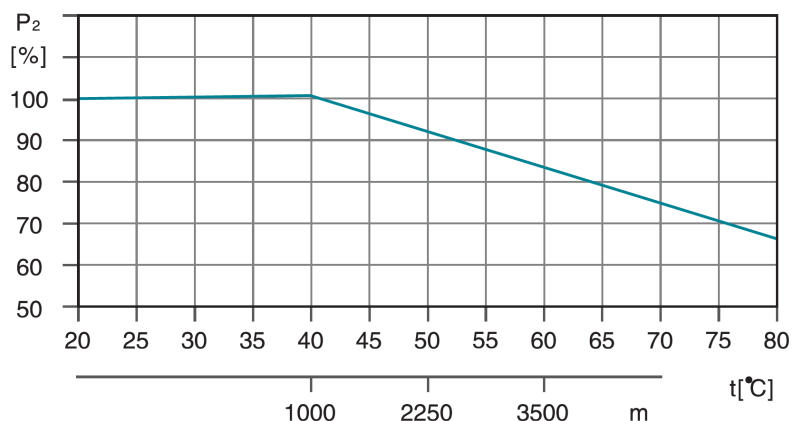

For example, when the pump is installed at an altitude of 3500 meters, P_2 will decrease by 88%. And when the ambient temperature is 70 ° C, P_2 will decrease by 78%.

Maximum Operation pressure (bar)

The table below shows the maximum discharge pressures of the various LVS (R) pumps. The suction pressure of the pump + the set pressure must always be lower than the maximum operating pressure of the pump. If the maximum working pressure is exceeded, it can damage the motor bearings and reduce the service life of the mechanical seal.

Model	LVR Max. Operation pressure [bar]		LVS Max. Operation pressure [bar]
	Oval Flange	DIN Flange	
LVR (S) 1	16	25	25
LVR (S) 2	16	25	25
LVR (S) 3	16	25	25
LVR (S) 4	16	25	25
LVR (S) 5	16	25	25
LVR (S) 10		25	25
LVR (S) 15		25	25
LVR (S) 20		25	25
LVR (S) 32-1-1 - 32-7	16		16
LVR (S) 32-8-2 - 32-14	30		30
LVR (S) 45-1-1 - 45-5	16		16
LVR (S) 45-6-2 - 45-11	30		30
LVR (S) 45-12-2 - 45-13-2	33		33
LVR (S) 64-1-1 - 64-5	16		16
LVR (S) 64-6-2 - 64-8-1	30		30
LVR (S) 90-1-1 - 90-4	16		16
LVR (S) 90-5-2 - 90-6	30		30
LVR (S) 120-1 - 120-7	20		20
LVR (S) 150-1-1 - 150-6	20		20
LVR (S) 200-1-D - 200-4	20		20

NPSH

Minimum Inlet Pressure–Npsh

Calculation of the inlet pressure “H” is recommended in these situations:

- The liquid temperature is high.
- The flow is significantly higher than the rated flow.
- Water is drawn from depths.
- Water is drawn through long pipes.
- Inlet conditions are poor.

To avoid cavitation, make sure that there is a minimum pressure on the suction side of the pump. The maximum suction lift “H” in meters head can be calculated as follows:

$$H = P_b \times 10.2 - NPSH - H_f - H_v - H_s$$

P_b = Barometric pressure in bar. (Barometric pressure can be set to 1 bar). In closed systems, P_b indicates the system pressure in bar.

NPSH = Net Positive Suction Head in meters head. (To be read from the NPSH curve at the highest flow the pump will be delivering.)

H_f = Friction loss in suction pipe in meters head. (At the highest flow the pump will be delivering.)

H_v = Vapor pressure in meters head. (To be read from the vapor pressure scale. “ H_v ” depends on the liquid temperature “ t_m ”)

H_s = Safety margin=minimum 0.5 meters head.

If the “H” calculated is positive, the pump can operate at a suction lift of maximum “H” meters head.

If the “H” calculated is negative, an inlet pressure of minimum “H” meters head is required.



t_m [°C]	H_v [m]
190	126
180	100
170	79
160	62
150	45
140	40
140	35
130	30
130	25
120	20
110	15
100	12
100	10
90	8.0
90	6.0
80	5.0
80	4.0
70	3.0
60	2.0
50	1.5
50	1.0
40	0.8
40	0.6
30	0.4
30	0.3
20	0.2
10	0.1
0	0

Note: To avoid cavitation, never select a pump with a duty point too far to the right on the NPSH curve. Always check the NPSH value of the pump at the highest possible flow.

LVS150 Vertical multicellular stainless steel in line pump



Application

- Transfer of liquids with low viscosity, non-flammable and non-explosive, not containing solid particles or fibers. These liquids must not chemically attack the materials of the pump.
- Water supply for tall buildings, pumping stations, overpressure in drinking water
- Washing stations, heating water circulation, air conditioning water circulation, water treatment systems
- Ultrafiltration, reverse osmosis, distillation systems, municipal swimming pools
- Irrigation: sprinkling, drip
- Food industry
- Fire fighting systems

Pompe

- Liquid temperature: from -20°C to +120°C
- Nominal flow: 150 m³/h
- maximum pressure: 16 bars
- pH between 4 and 10

Moteur

- IE3 motor
- Protection class: IP55
- Maximum ambient temperature: +40°

Identification codes

LVS	150	-5	-2	-B	/F	
						DIN flange
						inox 316 (by default, inox 304)
						number of small impellers
						number of impellers
						Nominal flow (m ³ /h)
						Vertical multistage stainless steel in line pump

Technical data

MODEL	kW	Q (m³/h)	80	90	100	110	120	130	140	150	160	170	180
		Q (l/min)	1333	1500	1667	1833	2000	2167	2333	2500	2667	2833	3000
LVS150-1-1/F	11	18.3	17.8	17.3	17	16	15	14	12.5	11	10	8.5	
LVS150-1/F	15	24	23	22.5	22	21.5	20.5	20	18.5	17	16	15	
LVS150-2-1/F	22	44.3	43	42	40	39	28.5	37.5	35	33	30	27	
LVS150-2-2/F	18.5	37	35.5	34	33	32	31	29	27.5	26	23	21	
LVS150-2/F	30	50	49	48	47	45.5	44	42	40	37	34	32	
LVS150-3-1/F	37	70	68	67	65	63	62	60	56	53	49	45	
LVS150-3-2/F	30	63.5	61	59	57.5	56	54.5	53	49	45.5	42	39	
LVS150-3/F	37	78	76.5	75	73	70.5	68	66	63	59	55	50.5	
LVS150-4-1/F	45	96.5	94	91.5	89	86.5	84	81.5	77	72.5	67	62	
LVS150-4-2/F	45	89	87	84	81.5	79	77	74.5	70.5	65.5	60	56	
LVS150-4/F	55	104	102	100	97	95	91	88	84	79.5	74	68	
LVS150-5-1/F	75	112.5	119.5	117	113.5	111.5	107.5	104.5	99	93.5	87	80	
LVS150-5-2/F	55	115.5	112	109	106	102.5	100	97	92	86	79	73.5	
LVS150-5/F	75	130	127.5	125	121	119	115	111.5	106.5	101	94.5	86.5	
LVS150-6-1/F	75	148.5	145	141.7	137.5	135	131	127	120.5	114.5	106.5	97.5	
LVS150-6-2/F	75	140	137	133	130	126	121	118	112	106	98	91	
LVS150-6/F	75	157	153	149	145	142	139.5	137	130	123.5	116	109	

Hydraulic performance

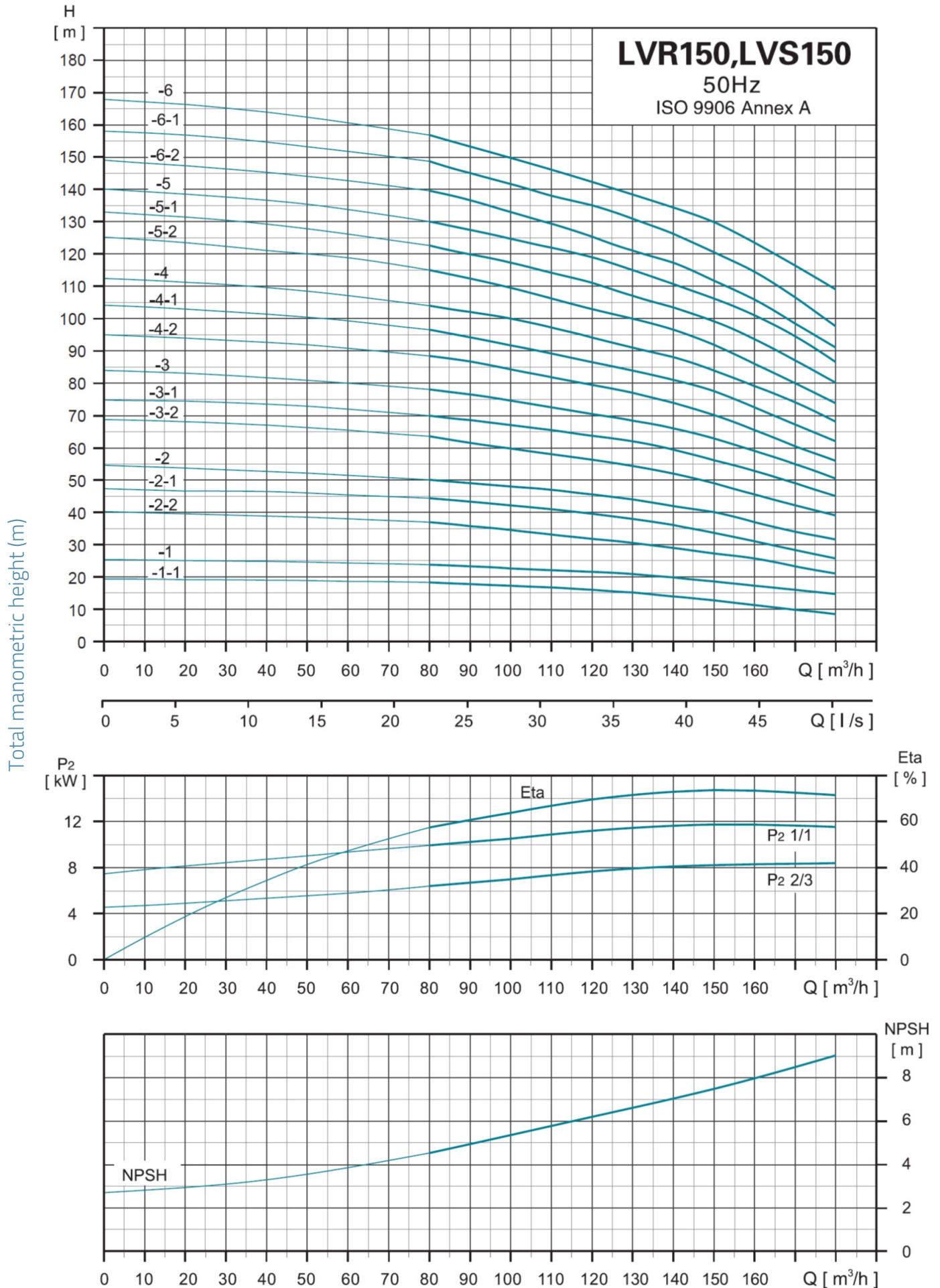

Dimensions

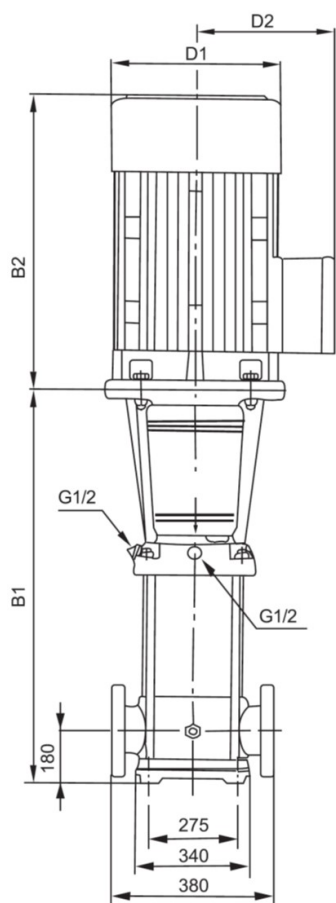

MODEL	B1	B1+B2	D1	D2	poids
LVS150-1-1/F	840	1339	254	175	186
LVS150-1/F	840	1339	254	175	200
LVS150-2-1/F	1000	1600	380	280	295
LVS150-2-2/F	1000	1560	330	250	250
LVS150-2/F	1000	1680	420	305	317
LVS150-3-1/F	1160	1840	420	305	360
LVS150-3-2/F	1160	1840	420	305	360
LVS150-3/F	1160	1840	420	305	385
LVS150-4-1/F	1320	2035	470	335	460
LVS150-4-2/F	1320	2035	470	335	460
LVS150-4/F	1320	2135	510	370	560
LVS150-5-1/F	1510	2355	580	410	690
LVS150-5-2/F	1510	2295	510	370	570
LVS150-5/F	1510	2355	580	410	690
LVS150-6-1/F	1670	2515	580	410	700
LVS150-6-2/F	1670	2515	580	410	700
LVS150-6/F	1670	2515	580	410	700

Exploded view

No.	Type	Materials
1	Base	cast iron HT200
2	Flange	ZG35 cast steel
3	Lower water box	ZG304
4	Diffuser	AISI 304 stainless steel
5	Intermediate diffuser	AISI 304 stainless steel
6	Diffuser with bearing	AISI 304 stainless steel
7	Impeller	AISI 304 stainless steel
8	Diffuser	AISI 304 stainless steel
9	Pump bottom	ZG304
10	Lantern	cast iron HT200
11	Engine	
12	Coupling	QT400 cast iron
13	Coupling protection housing	AISI 304 stainless steel
14	Cartridge mechanical seal	
15	Filling plug	AISI 304 stainless steel
16	Jacket	AISI 304 stainless steel
17	Clamping plate	AISI 304 stainless steel
18	Pump shaft	AISI 304 stainless steel

