

# Motore a 2 poli per pompe in linea LPP

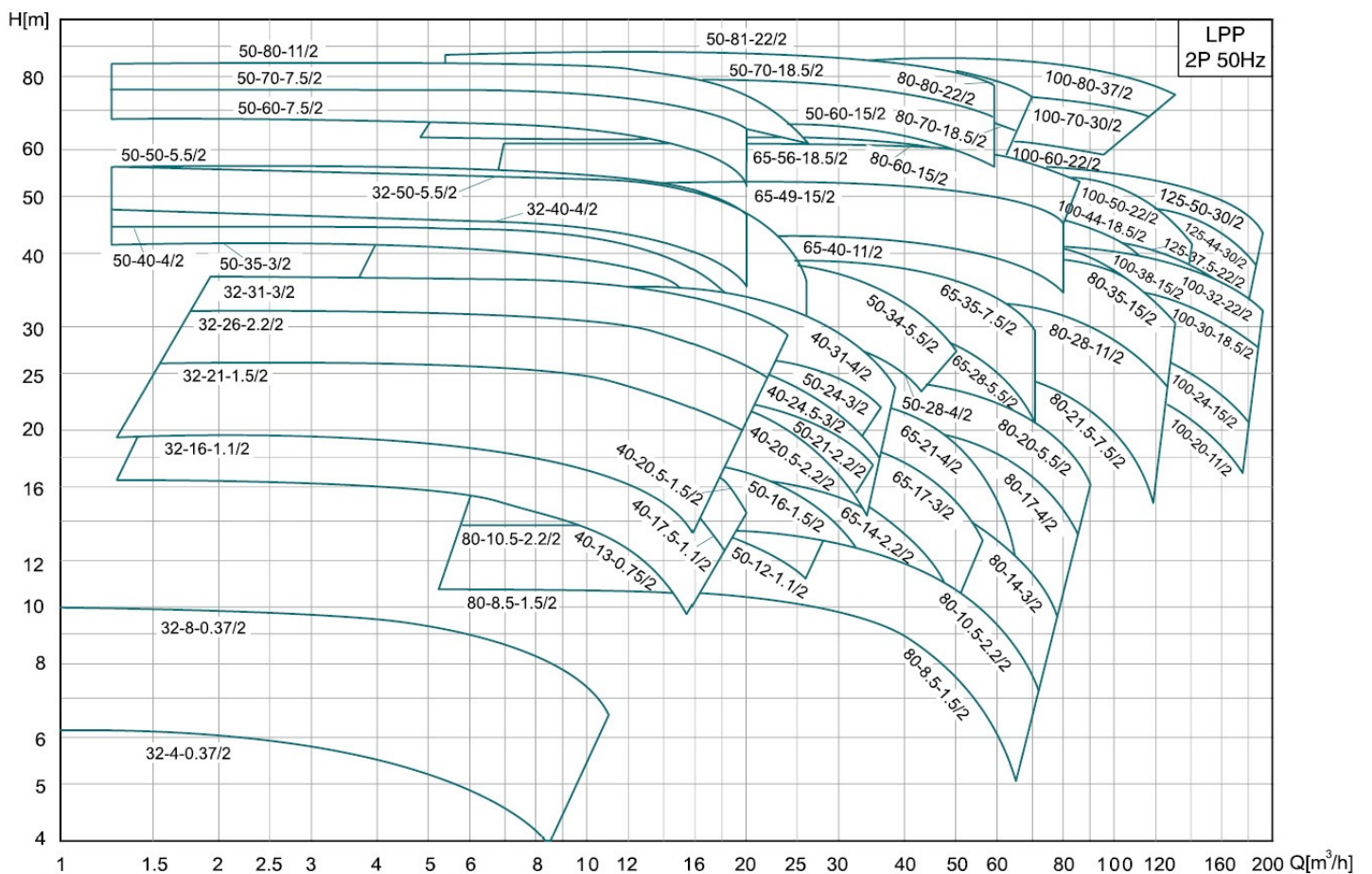

## Modelli di pompe in linea LPP

MODELES	Puissance P2(kW)	Vitesse (Tr/min)	Débit nominal (m3/h)	Pression nominale (mce)	Débit Max (m3/h)	Pression Max (mce)
LPP32-8-0.37/2**	0.37	2900	8.5	8	11	10
LPP32-4-0.37/2**	0.37	2900	7.5	4	8.5	6
LPP32-31-3/2	3	2900	20	31	24	37
LPP32-26-2.2/2	2.2	2900	18	26	21	32
LPP32-21-1.5/2	1.5	2900	14	21	18.5	26
LPP32-16-1.1/2	1.1	2900	12	16	16	20
LPP32-50-5.5/2•	5.5	2900	12.5	50	20	53.5
LPP32-40-4/2•	4	2900	12.5	40	20	46
LPP40-20.5-1.5/2	1.5	2900	12	20.5	20	25
LPP40-17.5-1.1/2	1.1	2900	12	17.5	18	21
LPP40-13-0.75/2	0.75	2900	10	13	15.5	16.5
LPP40-31-4/2	4	2900	26	31	38	35
LPP40-24.5-3/2	3	2900	24	24.5	36	28
LPP40-20.5-2.2/2	2.2	2900	23	20.5	35	25
LPP50-24-3/2	3	2900	30	24	36	29
LPP50-21-2.2/2	2.2	2900	24	21	35	25
LPP50-16-1.5/2	1.5	2900	22	16	32	19
LPP50-12-1.1/2	1.1	2900	20	12	26	15
LPP50-34-5.5/2	5.5	2900	35	34	50	42
LPP50-28-4/2	4	2900	30	28	43	33
LPP50-50-5.5/2•	5.5	2900	12.5	50	26	54
LPP50-40-4/2•	4	2900	12.5	40	26	42
LPP50-35-3/2•	3	2900	12.5	35	20	40
LPP50-80-11/2•	11	2950	12.5	80	26	81.5
LPP50-70-7.5/2•	7.5	2950	12.5	70	20	73
LPP50-60-7.5/2•	7.5	2950	12.5	60	20	63
LPP50-81-22/2	22	2950	50	81	59	88
LPP50-70-18.5/2	18.5	2950	50	70	59	78
LPP50-60-15/2	15	2950	50	60	59	67
LPP65-35-7.5/2	7.5	2900	55	35	70	39
LPP65-28-5.5/2	5.5	2900	50	28	70	30
LPP65-21-4/2	4	2900	45	21	60	24
LPP65-17-3/2	3	2900	40	17	56	20
LPP65-14-2.2/2	2.2	2900	35	14	50	17
LPP65-56-18.5/2	18.5	2950	70	56	86	61
LPP65-49-15/2	15	2950	65	49	80	53
LPP65-40-11/2	11	2950	56	40	80	43
LPP80-20-5.5/2	5.5	2900	70	20	90	25
LPP80-17-4/2	4	2900	64	17	79	21
LPP80-14-3/2	3	2900	55	14	75	17
LPP80-10.5-2.2/2	2.2	2900	52	10.5	70	14
LPP80-8.5-1.1/2	1.5	2900	45	8.5	65	10.5
LPP80-35-15/2	15	2950	110	35	130	42
LPP80-28-11/2	11	2950	100	28	125	35
LPP80-21.5-7.5/2	7.5	2950	90	21.5	119	28
LPP80-80-22/2	22	2950	50	80	70	86
LPP80-70-18.5/2	18.5	2950	45	70	65	75
LPP80-60-15/2	15	2950	40	60	60	63
LPP100-32-22/2	22	2950	170	32	190	43
LPP100-30-18.5/2	18.5	2950	160	30	179	38
LPP100-24-15/2	15	2950	150	24	180	31
LPP100-20-11/2	11	2950	135	20	175	28
LPP100-80-37/2	37	2950	100	80	130	86
LPP100-70-30/2	30	2950	90	70	120	76
LPP100-60-22/2	22	2950	80	60	96	64
LPP100-50-22/2	22	2950	100	50	140	56
LPP100-44-18.5/2	18.5	2950	90	44	140	47
LPP100-38-15/2	15	2950	85	38	130	43
LPP125-50-30/2	30	2950	160	50	190	58
LPP125-44-30/2	30	2950	150	44	190	52
LPP125-37.5-22/2	22	2950	135	37.5	180	45

**LPP40** Pompe centrifughe in linea in ghisa**Application**

- Pompe centrifughe in linea con costruzione in ghisa. Particolarmente adatto per impianti di condizionamento e trasferimento di acqua calda o fredda.

**Pompe**

- Portata fino a: 38 m<sup>3</sup> / h
- Pressione massima: 35 metri
- Temperatura del liquido: da 0 ° C a + 90 ° C

**Moteur**

- Motore IE3
- Classe di protezione : IP55
- Temperatura ambiente massima: + 40 °

**Codici identificativi**

<b>LPP</b>	<b>40</b>	<b>13</b>	<b>0,75</b>	<b>2</b>	
					numero di poli motore
					potenza motore (kW)
					pressione nominale (m)
					diametro ingresso / uscita (mm)
					Pompa in linea verticale

# Prestazioni idrauliche

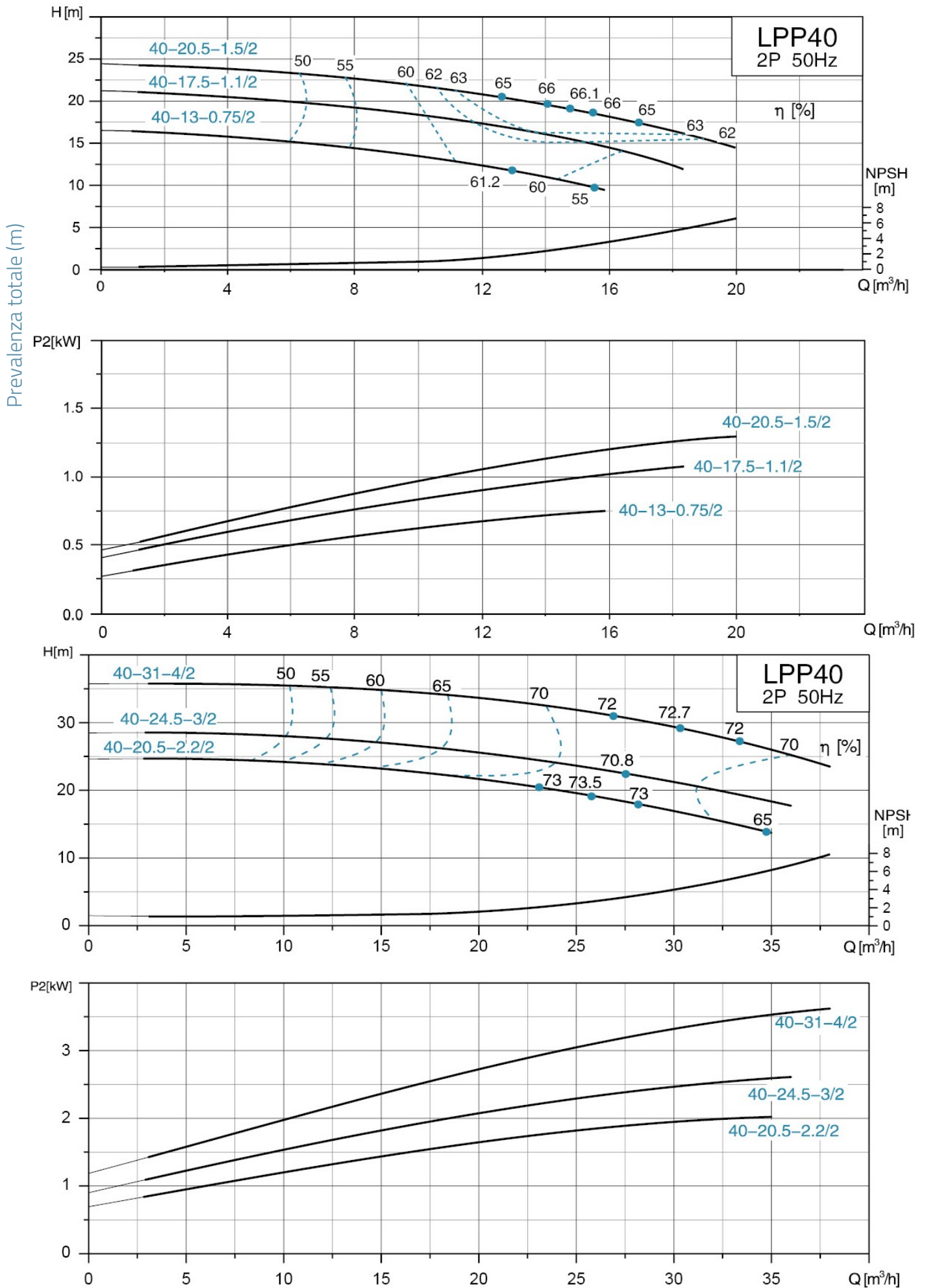

# Dimensioni

## LPP40 (motori da 0,75 a 4kW)

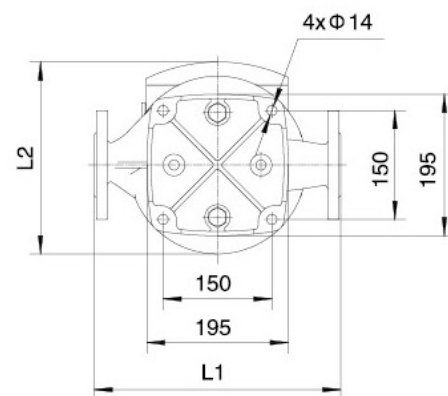
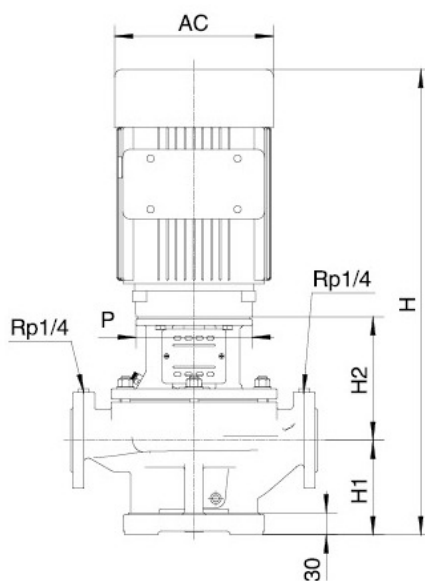
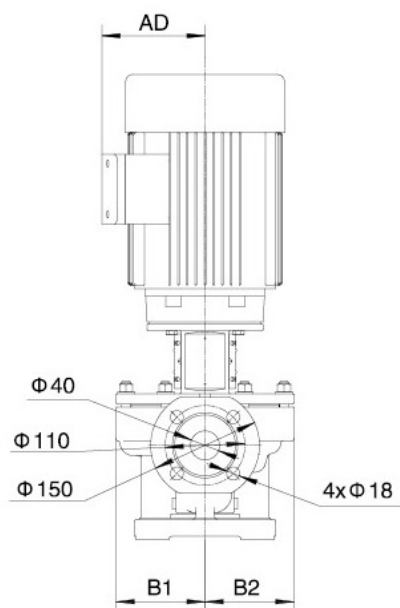

MODEL	L1	L2	H	H1	H2	B1	B2	P	AD	AC
<b>LPP40-13-0.75/2</b>	340	247.5	561.5	130	161	123	123	120	124.5	150
<b>LPP40-17.5-1.1.1/2</b>	340	247.5	561.5	130	161	123	123	120	124.5	150
<b>LPP40-20.5-1.5/2</b>	340	250.5	610.5	130	161	123	123	140	124.5	164
<b>LPP40-20.5-2.2/2</b>	340	246	642.5	130	170	123	123	160	119.5	186
<b>LPP40-24.5-3/2</b>	340	246	642.5	130	170	123	123	160	119.5	186
<b>LPP40-31-4/2</b>	340	246	642.5	130	170	123	123	140	119.5	164

## Vista esplosa



No.	Type	materiale
1	corpo pompa	ghisa HT200
2	turbina	ghisa HT200
3	tenuta meccanica	carburo di silicio / grafite
4	albero della pompa	Acciaio inossidabile AISI 304
5	accoppiamento	acciaio
6	lanterna	ghisa HT200
7	motore	