

3(4,5)ACSms centrifugal pump Self-priming multicellulaire en fonte

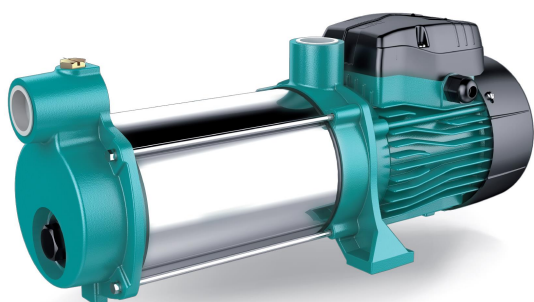

Application

- Transfer of clear water or other liquids chemically and physically comparable to water
- Suitable for industrial use and water supply, overpressure, long distance water transfer, etc ...

Pompe

- Self-priming
- Stainless steel lined pump body
- Special anti-rust treatment (cataphoresis) of cast iron parts
- AISI 304 stainless steel shaft
- Maximum liquid temperature: +40°C
- Maximum suction height: 8 m

Moteur

- Integrated thermal protection for single-phase motors
- Insulation class: F
- Protection class: IPX4
- Maximum ambient temperature: +40°C
- IE2 motor (three-phase, motor > 0.75 kW)

Identification codes

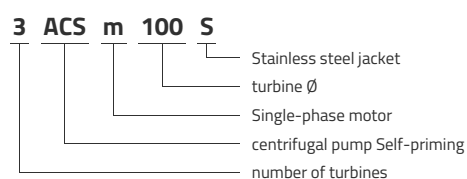

Technical data

MODEL	kW	Q (m³/h)											
		0	0.6	1.2	2.1	2.4	3	3.6	4.2	4.8	5.4	6	
		Q (l/min)											
		0	10	20	35	40	50	60	70	80	90	100	
3ACSms100S	0.6	35	33.5	31.5	29	26.5	24	20.5	16	12	7		
3ACS100S	0.6	35	33.5	31.5	29	26.5	24	20.5	16	12	7		
4ACSms100S	0.75	45	41	38.5	36	33	30	25.5	21	15	9		
4ACS100S	0.75	45	41	38.5	36	33	30	25.5	21	15	9		
5ACSms100S	0.9	55	54	52	49	45	40	35	29	22.5	15	8	
5ACS100S	0.9	55	54	52	49	45	40	35	29	22.5	15	8	

Dimensions

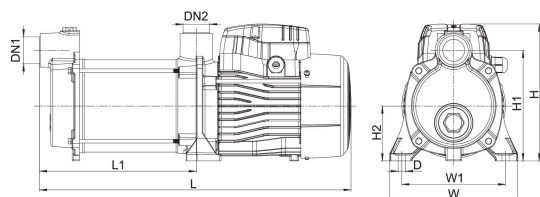

MODEL	DN1	DN2	L	L1	W	W1	H	H1	H2	D
3ACSms100S	1	1	429	216	176	140	187	151	75	10
3ACS100S	1	1	429	216	176	140	187	151	75	10
4ACSms100S	1	1	453	240	176	140	187	151	75	10
4ACS100S	1	1	453	240	176	140	187	151	75	10
5ACSms100S	1	1	477	264	176	140	187	151	75	10
5ACS100S	1	1	477	264	176	140	187	151	75	10

Hydraulic performance

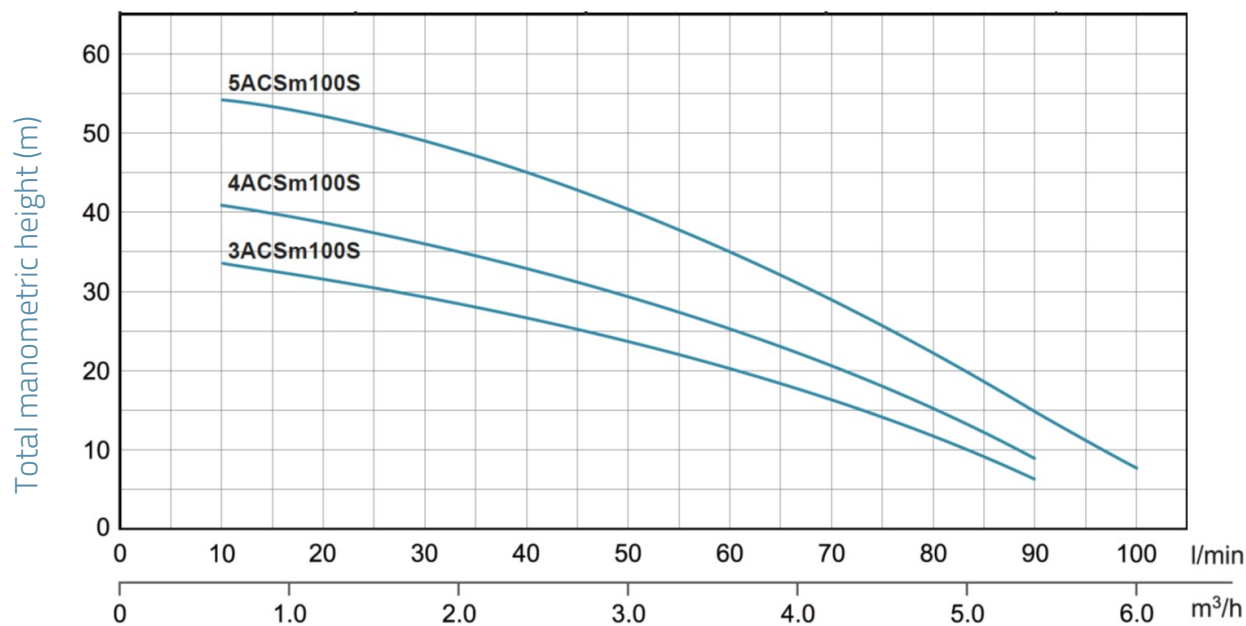

Exploded view

No.	Type	Materials
1	Plug	cast iron HT200
2	Non-return valve	nitrile rubber (NBR)
3	Check valve spring	AISI 304 stainless steel
4	Valve seat	noryl (PPO)
5	Pump body	noryl (PPO)
6	O-ring	noryl (PPO)
7	Jacket	AISI 304 stainless steel
8	Front plate	noryl (PPO)
9	Impeller	noryl (PPO)
10	Diffuser	noryl (PPO)
11	Diffuser	noryl (PPO)
12	Mechanical seal	carbon / ceramic
13	Rear pump body - lantern	cast iron HT200
14	Rubber washer	nitrile rubber (NBR)
15	Fan cover	polycarbonate/ABS
16	Fan	noryl (PPO)
17	Rear cover	cast aluminum ZL102
18	Wavy washer	65Mn steel
19	Cable gland	
20	Electric box cover	PA6 resin
21	Capacitor	
22	Terminal board	
23	Stator	
24	Bearing	
25	Rotor	

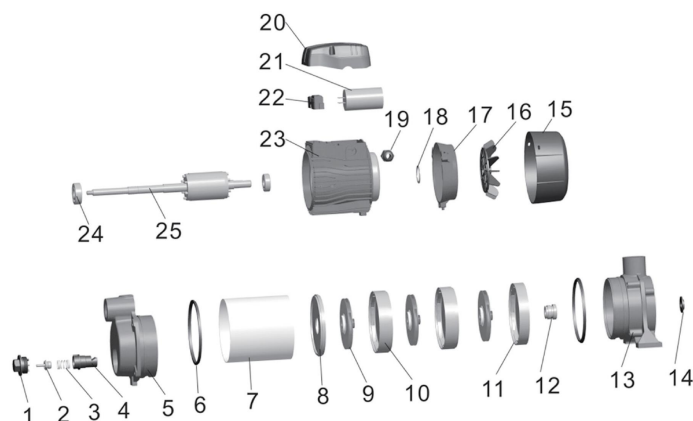

Packaging

MODEL	Weight (kg)	Length L (mm)	Width W (mm)	Height H (mm)
3ACSm100S	13.3	455	215	230
3ACS100S	13.1	455	210	230
4ACSm100S	14.5	480	215	230
4ACS100S	14.1	480	210	230
5ACSm100S	15.4	505	215	230
5ACS100S	15.1	505	210	230

