

ECH2-D Horizontal multistage stainless steel pump

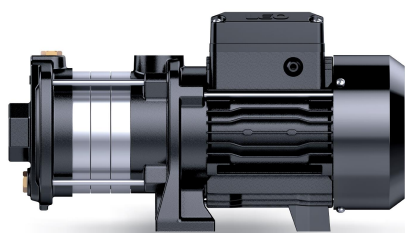

Application

- Water supply for tall buildings, pumping stations, overpressure
- Washing stations, heating water circulation, air conditioning water circulation, water treatment systems
- Ultrafiltration, reverse osmosis, distillation systems, municipal swimming pools
- Irrigation: sprinkling, drip
- Industry
- Fire fighting systems

Pompe

- Stainless steel shaft
- Max liquid temperature: +40°C
- Max suction height: 8 m
- Maximum operating pressure: 8 bars
- pH between 6,5 and 8,5

Moteur

- IE3 motor
- Protection class: IP55
- Insulation class: F
- Maximum ambient temperature: +40°
- Integrated thermal protection for single-phase versions
- Altitude: up to 1000 m

Identification codes

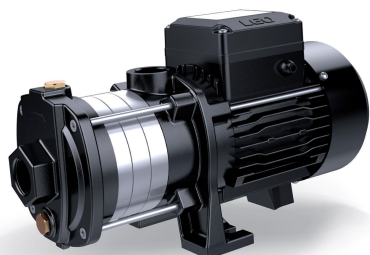
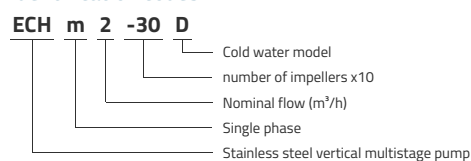

Technical data

MODEL	kW	Q (m ³ /h)						
		0.6	1.2	1.8	2.4	3	3.6	
		Q (l/min)	10	20	30	40	50	60
ECHm2-20D	0.37	16	15	13	12	10	8	
ECH2-20D	0.37	16	15	13	12	10	8	
ECHm2-30D	0.37	24	22	20	18	16	12	
ECH2-30D	0.37	24	22	20	18	16	12	
ECHm2-40D	0.55	33	30	26	24	21	16	
ECH2-40D	0.55	33	30	26	24	21	16	

Dimensions

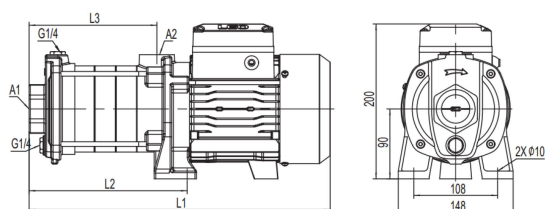

MODEL	L1	L2	L3	A1	A2
ECHm2-20D	324	140	101	1	1
ECH2-20D	324	140	101	1	1
ECHm2-30D	342	158	119	1	1
ECH2-30D	342	158	119	1	1
ECHm2-40D	360	176	137	1	1
ECH2-40D	360	176	137	1	1

Hydraulic performance

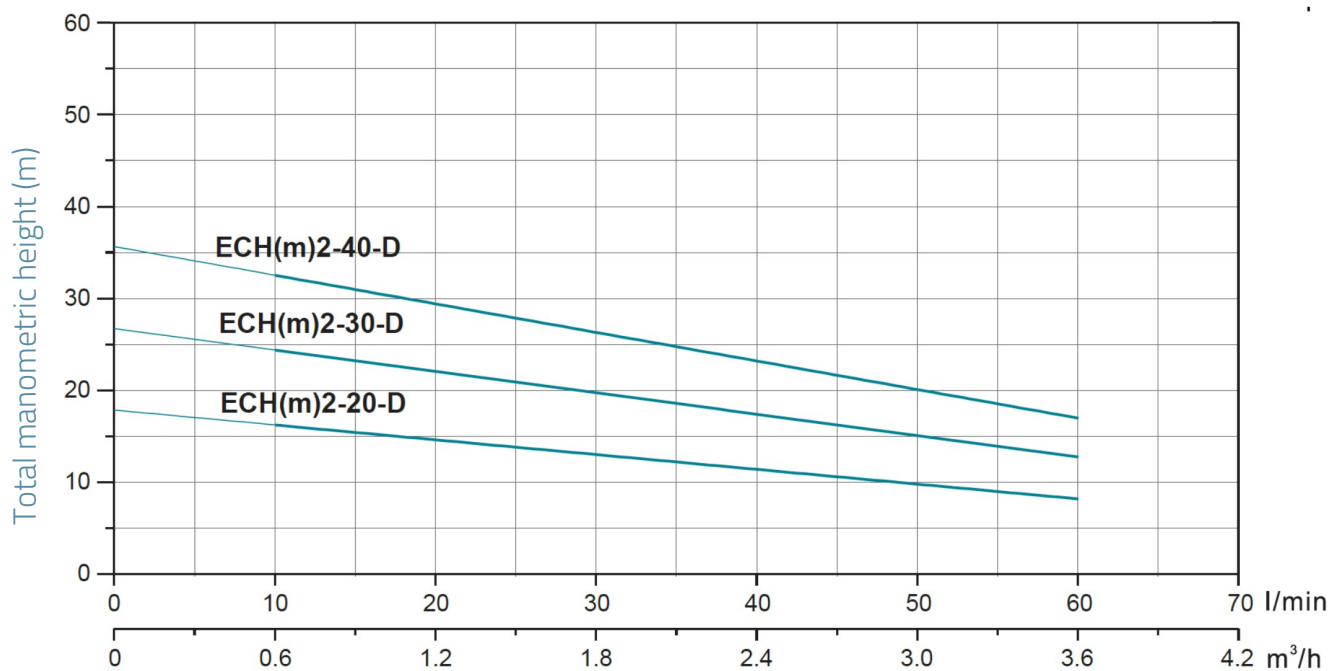

Exploded view

No.	Type	Materials
1	Front cover	cast iron HT200
2	Positioning sleeve	AISI 304 stainless steel
3	Circlip	PolyTetraFluoroEthylene
4	Diffuser	AISI 304 stainless steel
5	Impeller	AISI 304 stainless steel
6	Muff	AISI 304 stainless steel
7	Mechanical seal	silicon carbide / graphite
8	Fan cover	O8F steel
9	Fan	polypropylene
10	Rear cover	cast aluminum ZL102
11	Bearing	
12	Stator	
13	Rotor	
14	Lantern	cast iron HT200
15	Circlip	PolyTetraFluoroEthylene
16	Leg	PolyTetraFluoroEthylene

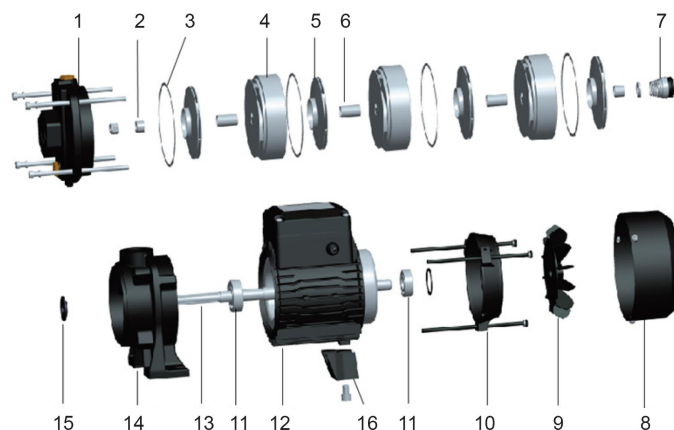

Packaging

MODEL	Weight (kg)	Length L (mm)	Width W (mm)	Height H (mm)
ECHm2-20D	10.7	375	185	237
ECH2-20D	10.3	375	185	237
ECHm2-30D	11	375	185	237
ECH2-30D	10.7	375	185	237
ECHm2-40D	12.6	420	185	237
ECH2-40D	12.4	420	185	237

