

### Scope of Performance LVS (R)

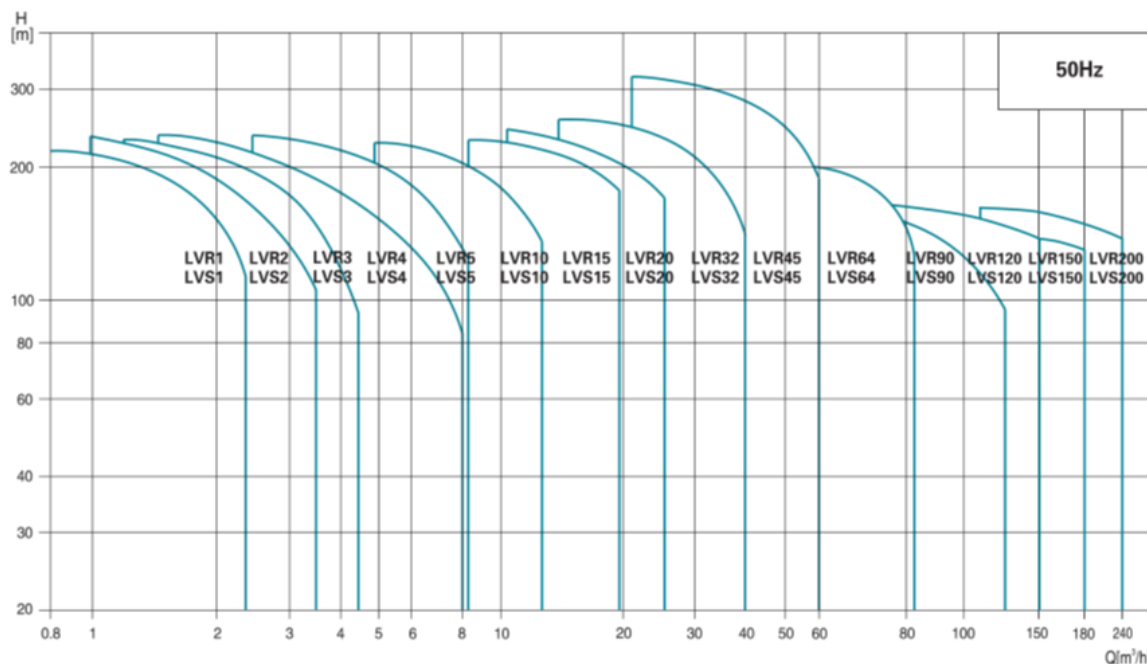

### Product Range

MODEL	LVR(S)1	LVR(S)2	LVR(S)3	LVR(S)4	LVR(S)5	LVR(S)10	LVR(S)15	LVR(S)20	LVR(S)32	LVR(S)45	LVR(S)64	LVR(S)90	LVR(S)120	LVR(S)150	LVR(S)200
<b>DESCRIPTION</b>															
Rated flow [m³/h]	1	2	3	4	5	10	15	20	32	45	64	90	120	150	200
Flow range [m³/h]	0.7-2.4	1.0-3.5	1.2-4.5	1.5-8	2.5-8.5	5-13	8-23	10.5-29	15-40	22-58	30-85	45-120	60-150	80-180	100-240
Max. pressure [bar]	22	23	24	21	24	22	23	25	28	33	22	20	16	16	16
Motor power [kW]	0.37-2.2	0.37-3	0.37-3	0.37-4	0.37-4	1.1-7.5	1.1-15	1.1-18.5	1.5-30	3-45	4-45	5.5-45	11-75	11-75	18.5-110
Temperature Range [°C]	-20°C--+120°C ( Note: Both the Max. permissible pressure and liquid temperature range refer to the pump capacity.)														
Max. pump efficiency [%]	45	46	55	59	60	65	70	72	78	79	80	81	74	73	79
Pipe connection-LVR															
Oval flange	G1	G1	G1	G1 1/4	G1 1/4	-	-	-	-	-	-	-	-	-	-
DIN flange	DN25	DN25	DN25	DN32	DN32	DN40	DN50	DN50	DN65	DN80	DN100	DN100	DN125	DN125	DN150
Pipe connection-LVS															
Oval flange	-	-	-	-	-	-	-	-	-	-	-	-	-	-	-
DIN flange	DN32	DN32	DN32	DN32	DN32	DN40	DN50	DN50	DN65	DN80	DN100	DN100	DN125	DN125	DN150
Clamp connector	φ42	φ42	φ42	φ42	φ42	-	-	-	-	-	-	-	-	-	-
Threaded connector	R <sub>2</sub> 1 1/4	R <sub>2</sub> 1 1/4	R <sub>2</sub> 1 1/4	R <sub>2</sub> 1 1/4	R <sub>2</sub> 1 1/4	-	-	-	-	-	-	-	-	-	-

## Ambient Temperature

An ambient temperature of over 40 ° C or an installation at an altitude above 1000 meters above sea level requires an oversized motor. Due to low air density and poor cooling, the output power P<sub>2</sub> decreases, as shown in the table below:

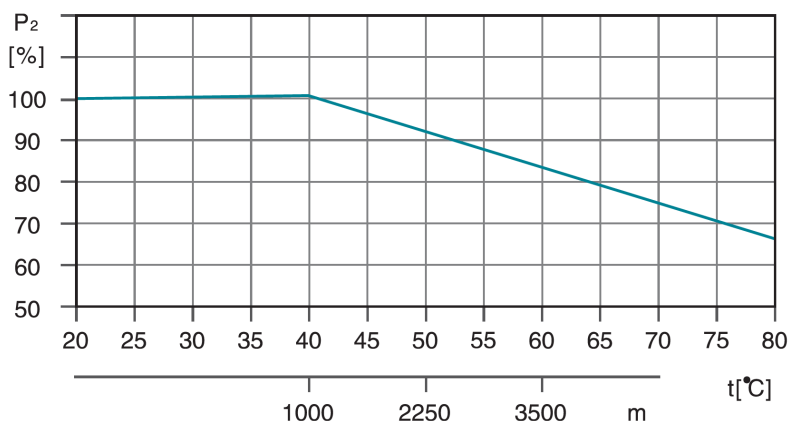

For example, when the pump is installed at an altitude of 3500 meters, P<sub>2</sub> will decrease by 88%. And when the ambient temperature is 70 ° C, P<sub>2</sub> will decrease by 78%.

## Maximum Operation pressure (bar)

The table below shows the maximum discharge pressures of the various LVS (R) pumps. The suction pressure of the pump + the set pressure must always be lower than the maximum operating pressure of the pump. If the maximum working pressure is exceeded, it can damage the motor bearings and reduce the service life of the mechanical seal.

Model	LVR Max. Operation pressure [bar]		LVS Max. Operation pressure [bar]
	Oval Flange	DIN Flange	
LVR (S) 1	16	25	25
LVR (S) 2	16	25	25
LVR (S) 3	16	25	25
LVR (S) 4	16	25	25
LVR (S) 5	16	25	25
LVR (S) 10		25	25
LVR (S) 15		25	25
LVR (S) 20		25	25
LVR (S) 32-1-1 - 32-7	16		16
LVR (S) 32-8-2 - 32-14	30		30
LVR (S) 45-1-1 - 45-5	16		16
LVR (S) 45-6-2 - 45-11	30		30
LVR (S) 45-12-2 - 45-13-2	33		33
LVR (S) 64-1-1 - 64-5	16		16
LVR (S) 64-6-2 - 64-8-1	30		30
LVR (S) 90-1-1 - 90-4	16		16
LVR (S) 90-5-2 - 90-6	30		30
LVR (S) 120-1 - 120-7	20		20
LVR (S) 150-1-1 - 150-6	20		20
LVR (S) 200-1-D - 200-4	20		20

## NPSH

### Minimum Inlet Pressure–Npsh

Calculation of the inlet pressure “H” is recommended in these situations:

- The liquid temperature is high.
- The flow is significantly higher than the rated flow.
- Water is drawn from depths.
- Water is drawn through long pipes.
- Inlet conditions are poor.

To avoid cavitation, make sure that there is a minimum pressure on the suction side of the pump. The maximum suction lift “H” in meters head can be calculated as follows:

$$H = P_b \times 10.2 - NPSH - H_f - H_v - H_s$$

$P_b$  = Barometric pressure in bar. (Barometric pressure can be set to 1 bar). In closed systems,  $P_b$  indicates the system pressure in bar.

**NPSH** = Net Positive Suction Head in meters head. (To be read from the NPSH curve at the highest flow the pump will be delivering.)

$H_f$  = Friction loss in suction pipe in meters head. (At the highest flow the pump will be delivering.)

$H_v$  = Vapor pressure in meters head. (To be read from the vapor pressure scale. “ $H_v$ ” depends on the liquid temperature “ $t_m$ ”)

$H_s$  = Safety margin=minimum 0.5 meters head.

If the “H” calculated is positive, the pump can operate at a suction lift of maximum “H” meters head.

If the “H” calculated is negative, an inlet pressure of minimum “H” meters head is required.

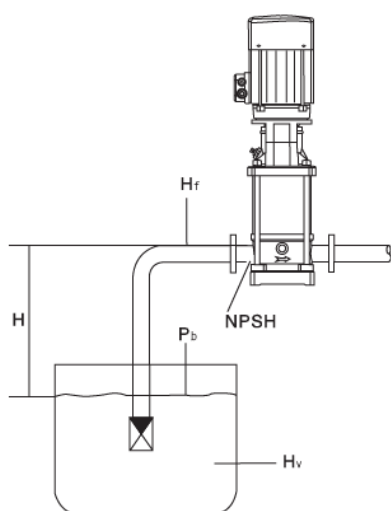

$t_m$ [°C]	$H_v$ [m]
190	126
180	100
170	79
160	62
150	45
140	40
140	35
130	30
130	25
120	20
110	15
100	12
100	10
90	8.0
90	6.0
80	5.0
80	4.0
70	3.0
60	2.0
50	1.5
50	1.0
40	0.8
40	0.6
30	0.4
30	0.3
20	0.2
10	0.1
0	0

**Note:** To avoid cavitation, never select a pump with a duty point too far to the right on the NPSH curve. Always check the NPSH value of the pump at the highest possible flow.

## LVS45 Vertical multicellular stainless steel in line pump



### Application

- Transfer of liquids with low viscosity, non-flammable and non-explosive, not containing solid particles or fibers. These liquids must not chemically attack the materials of the pump.
- Water supply for tall buildings, pumping stations, overpressure in drinking water
- Washing stations, heating water circulation, air conditioning water circulation, water treatment systems
- Ultrafiltration, reverse osmosis, distillation systems, municipal swimming pools
- Irrigation: sprinkling, drip
- Food industry
- Fire fighting systems

### Pompe

- Liquid temperature: from  $-20^{\circ}\text{C}$  to  $+120^{\circ}\text{C}$
- Nominal flow:  $45\text{ m}^3/\text{h}$
- maximum pressure: 33 bars
- pH between 4 and 10

### Moteur

- IE3 motor
- Protection class: IP55
- Maximum ambient temperature:  $+40^{\circ}$

### Identification codes

<b>LVS</b>	<b>45</b>	<b>-5</b>	<b>-2</b>	<b>-B</b>	<b>/F</b>	
						DIN flange
						inox 316 (by default, inox 304)
						number of small impellers
						number of impellers
						Nominal flow ( $\text{m}^3/\text{h}$ )
						Vertical multistage stainless steel in line pump

## Technical data

MODEL	kW	Q (m <sup>3</sup> /h)	25	30	35	40	45	50	55
		Q (l/min)	417	500	583	667	750	833	917
LVS <sub>m</sub> 45-1-1/F	3	20	19.5	18	17	15	12.5	10.5	
LVS45-1-1/F	3	20	19.5	18	17	15	12.5	10.5	
LVS <sub>m</sub> 45-1/F	4	24	23	22	20.5	19	17.5	15	
LVS45-1/F	4	24	23	22	20.5	19	17.5	15	
LVS45-2-2/F	5.5	41	39	37	34	30.5	26.5	22	
LVS45-2/F	7.5	48.5	46.5	44.5	42	39	35	31	
LVS45-3-2/F	11	66	64	61	56.5	52	46	40	
LVS45-3/F	11	73.5	71	68	64	59.5	54	47.5	
LVS45-4-2/F	15	91	88	84	78.5	72	64.5	56	
LVS45-4/F	15	98.5	95	91	85.5	79.5	72.5	64	
LVS45-5-2/F	18.5	116	113	107	101	92.5	83.5	73	
LVS45-5/F	18.5	124	120	115	108	100	91.5	81	
LVS45-6-2/F	22	142	137	131	122	113	103	90	
LVS45-6/F	22	149	144	138	130	121	111	98	
LVS45-7-2/F	30	168	163	156	147	135	123	109	
LVS45-7/F	30	176	171	163	155	144	132	116	
LVS45-8-2/F	30	193	187	179	168	155	142	126	
LVS45-8/F	30	200	194	187	176	164	149	134	
LVS45-9-2/F	30	217	211	202	189	175	159	142	
LVS45-9/F	37	226	219	210	199	185	170	151	
LVS45-10-2/F	37	243	236	225	212	196	179	159	
LVS45-10/F	37	251	243	233	220	205	187	166	
LVS45-11-2/F	45	273	264	253	238	222	201	179	
LVS45-11/F	45	281	272	261	246	230	209	187	
LVS45-12-2/F	45	298	289	276	261	242	220	195	
LVS45-12/F	45	306	296	284	268	251	229	204	
LVS45-13-2/F	45	323	313	300	283	263	239	212	

## Hydraulic performance

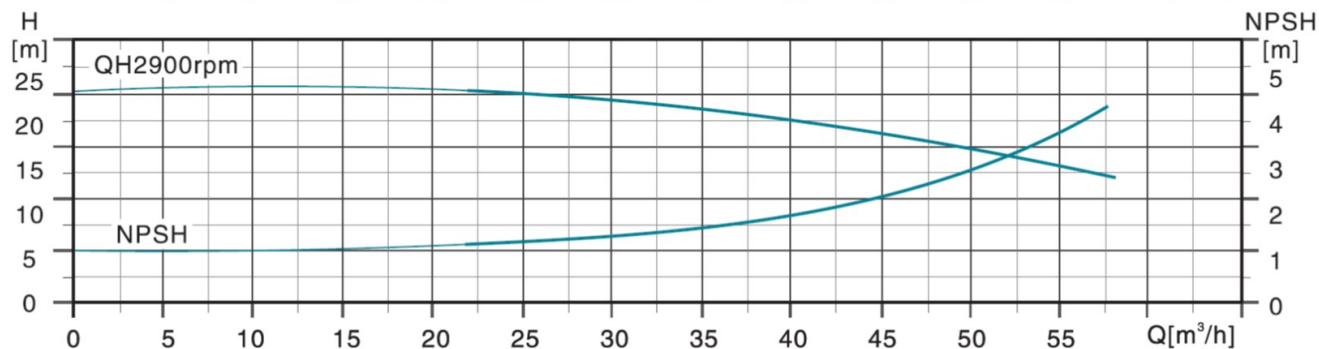
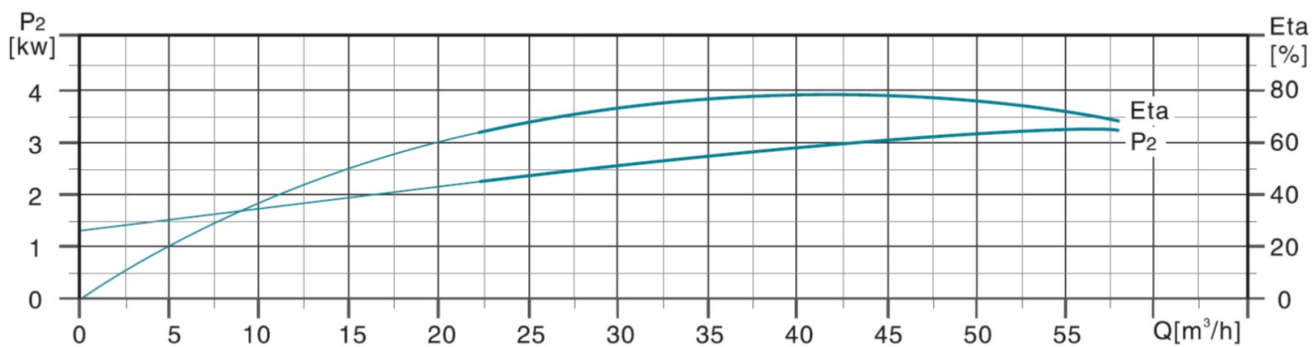
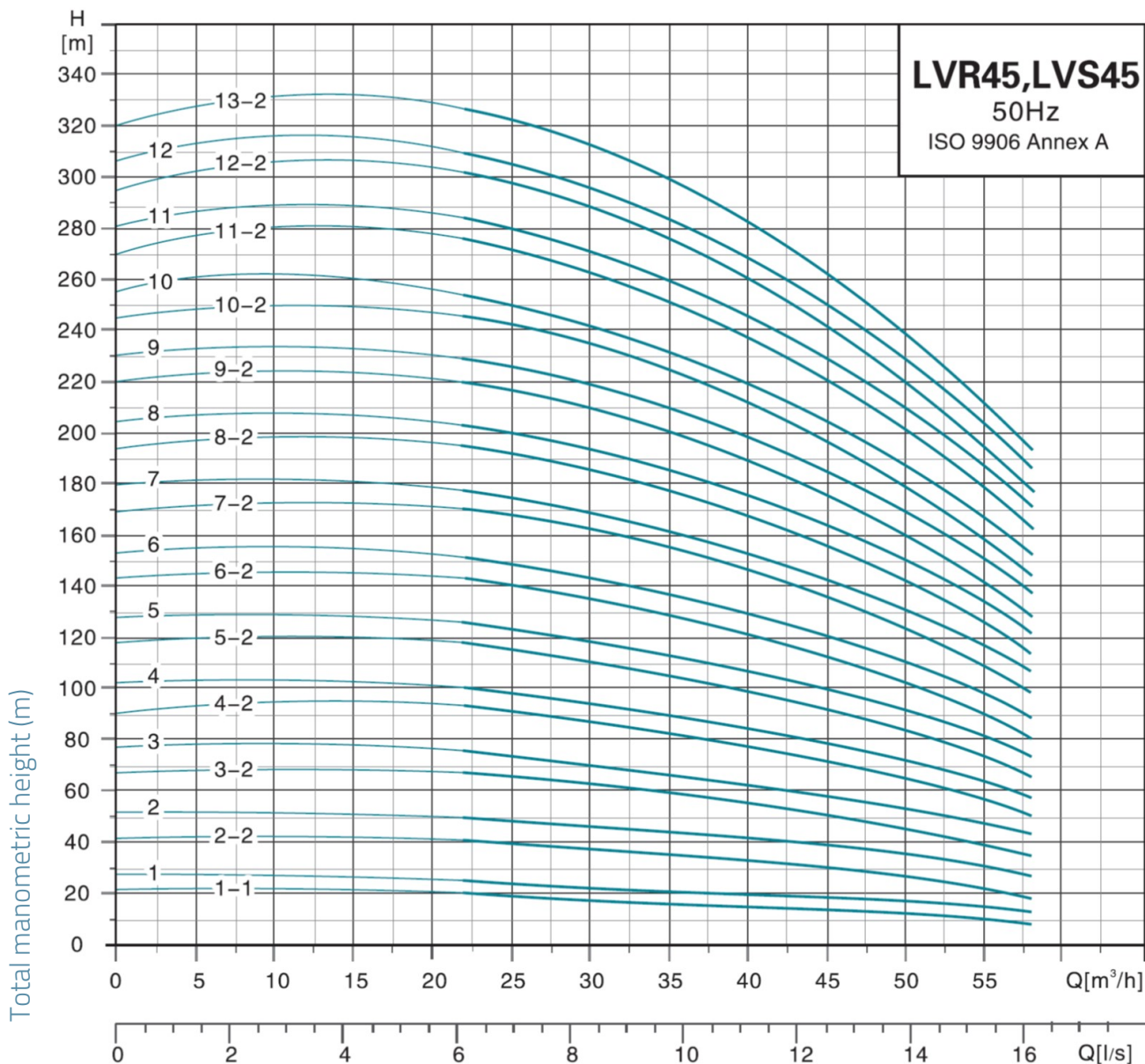

## Dimensions

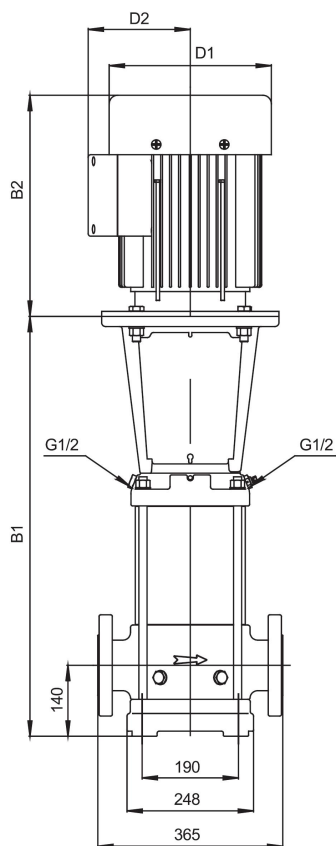

MODEL	B1	B1+B2	D1	D2	poids
<b>LVS45-1-1/F</b>					
LVS45-1-1/F	560	900	186	120	81
<b>LVS45-1/F</b>					
LVS45-1/F	560	900	186	120	83.2
<b>LVS45-2-2/F</b>					
LVS45-2-2/F	640	1037	210	142	111.3
<b>LVS45-2/F</b>					
LVS45-2/F	640	1037	210	142	115.5
<b>LVS45-3-2/F</b>					
LVS45-3-2/F	830	1329	254	175	157.6
<b>LVS45-3/F</b>					
LVS45-3/F	830	1329	254	175	157.6
<b>LVS45-4-2/F</b>					
LVS45-4-2/F	910	1409	254	175	173.1
<b>LVS45-4/F</b>					
LVS45-4/F	910	1409	254	175	173.1
<b>LVS45-5-2/F</b>					
LVS45-5-2/F	990	1550	330	250	225
<b>LVS45-5/F</b>					
LVS45-5/F	990	1550	330	250	225
<b>LVS45-6-2/F</b>					
LVS45-6-2/F	1070	1670	380	280	264.8
<b>LVS45-6/F</b>					
LVS45-6/F	1070	1670	380	280	264.8
<b>LVS45-7-2/F</b>					
LVS45-7-2/F	1150	1830	420	305	325.2
<b>LVS45-7/F</b>					
LVS45-7/F	1150	1830	420	305	325.2
<b>LVS45-8-2/F</b>					
LVS45-8-2/F	1230	1910	420	305	328.2
<b>LVS45-8/F</b>					
LVS45-8/F	1230	1910	420	305	328.2
<b>LVS45-9-2/F</b>					
LVS45-9-2/F	1310	1990	420	305	330.9
<b>LVS45-9/F</b>					
LVS45-9/F	1310	1990	420	305	349
<b>LVS45-10-2/F</b>					
LVS45-10-2/F	1390	2070	420	305	352.5
<b>LVS45-10/F</b>					
LVS45-10/F	1390	2070	420	305	352.5
<b>LVS45-11-2/F</b>					
LVS45-11-2/F	1470	2185	470	335	416.3
<b>LVS45-11/F</b>					
LVS45-11/F	1470	2185	470	335	416.3
<b>LVS45-12-2/F</b>					
LVS45-12-2/F	1550	2265	470	335	419.1
<b>LVS45-12/F</b>					
LVS45-12/F	1550	2265	470	335	419.1
<b>LVS45-13-2/F</b>					
LVS45-13-2/F	1630	2345	470	335	421.9

## Exploded view

No.	Type	Materials
1	Base	cast iron HT200
2	Flange	ZG35 cast steel
3	Lower water box	ZG304
4	Diffuser	AISI 304 stainless steel
5	Intermediate diffuser	AISI 304 stainless steel
6	Diffuser with bearing	AISI 304 stainless steel
7	Impeller	AISI 304 stainless steel
8	Shaft sleeve	
9	Diffuser	AISI 304 stainless steel
10	Drain plug	AISI 304 stainless steel
11	Lantern	cast iron HT200
12	Coupling protection housing	
13	Engine	AISI 304 stainless steel
14	Coupling	QT400 cast iron
15	Cartridge mechanical seal	
16	Pump bottom	ZG304
17	Filling plug	AISI 304 stainless steel
18	Clamping plate	AISI 304 stainless steel
19	Jacket	AISI 304 stainless steel
20	Pump shaft	AISI 304 stainless steel

